

A QUICK REVIEW OF TOPOLOGY

BOWEN LIU

CONTENTS

1. Fundamental group	2
1.A. Homotopy	2
1.B. Fundamental group	2
2. Covering space	7
2.A. Proper map	7
2.B. The lifting theorems	8
2.C. The classification of the covering spaces	10
2.D. The structure of the deck transformation group	11
2.E. Covering of manifold	12
3. Group action	14
3.A. Continuous action	14
3.B. Proper action	15
3.C. Properly discontinuous action	16
References	18

1. FUNDAMENTAL GROUP

1.A. Homotopy. In this section we assume $I = [0, 1]$, a path in a topological space X is a continuous map $\gamma : I \rightarrow X$ and a loop is a path γ such that $\gamma(0) = \gamma(1)$.

Definition 1.1 (homotopy). *Let X and Y be topological spaces and $f, g : X \rightarrow Y$ be continuous maps. A homotopy from f to g is a continuous map $F : X \times I \rightarrow Y$ such that for all $x \in X$, one has*

$$\begin{aligned} F(x, 0) &= f(x) \\ F(x, 1) &= g(x) \end{aligned}$$

If there exists a homotopy from f to g , then we say f and g are homotopic, and write $f \simeq g$.

Definition 1.2 (stationary homotopy). *Let X and Y be topological spaces and $A \subseteq X$ an arbitrary subset. A homotopy F between continuous maps $f, g : X \rightarrow Y$ is said to be stationary on A if*

$$F(x, t) = f(x)$$

for all $x \in A$ and $t \in I$. If there exists such a homotopy, then we say f and g are homotopic relative to A .

Remark 1.3. If f and g are homotopic relative to A , then f must agree with g on A .

Definition 1.4 (path homotopy). *Let X be a topological space and γ_1, γ_2 be two paths in X . They are said to be path homotopic if they are homotopic relative on $\{0, 1\}$, and write $\gamma_1 \simeq \gamma_2$.*

Definition 1.5 (loop homotopy). *Let X be a topological space and γ_1, γ_2 be two loops in X . They're called loop homotopic if they are homotopic relative on $\{0\}$, and write $\gamma_1 \simeq \gamma_2$.*

Remark 1.6. For convenience, if γ_1, γ_2 are paths (or loops), then when we say γ_1 is homotopic to γ_2 , we mean γ_1 is path (or loop) homotopic to γ_2 .

Definition 1.7 (free homotopy). *Let X be a topological space and γ_1, γ_2 be two loops in X . They are said to be free (loop) homotopic if they're homotopic through loops (but not necessarily preserving the base point), that is, there exists a homotopy $F(s, t) : [0, 1] \times [0, 1] \rightarrow X$ such that*

$$\begin{aligned} F(s, 0) &= \gamma_1(s) \\ F(s, 1) &= \gamma_2(s) \\ F(0, t) &= F(1, t) \text{ holds for all } t \in [0, 1] \end{aligned}$$

1.B. Fundamental group.

Proposition 1.8. *Let X be a topological space. For any $p, q \in X$, path homotopy is an equivalence relation on the set of all paths in X from p to q . For any path γ in X , the path homotopy class is denoted by $[\gamma]$.*

Proof. For path $\gamma : I \rightarrow X$, γ is homotopic to itself by $F(s, t) = \gamma(s)$. If γ_1 is homotopic to γ_2 by F , then γ_2 is homotopic to γ_1 by $G(s, t) = F(s, 1 - t)$. Finally, suppose γ_1 is homotopic to γ_2 by F , γ_2 is homotopic to γ_3 by G . Then consider

$$H = \begin{cases} F(s, 2t) & 0 \leq t \leq \frac{1}{2} \\ G(s, 2t - 1) & \frac{1}{2} \leq t \leq 1 \end{cases}$$

which is a homotopy from γ_1 to γ_3 . This shows path homotopy is an equivalence relation. \square

Definition 1.9 (reparametrization). A reparametrization of a path $f : I \rightarrow X$ is of the form $f \circ \varphi$ for some continuous map $\varphi : I \rightarrow I$ fixing 0 and 1.

Lemma 1.10. Any reparametrization of a path f is homotopic to f .

Proof. Suppose $f \circ \varphi$ is a reparametrization of f , and let $F : I \times I \rightarrow I$ denote the straight-line homotopy from the identity map to φ , that is, $F(s, t) = t\varphi(s) + (1-t)s$. Then $f \circ F$ is a path homotopy from f to $f \circ \varphi$. \square

Definition 1.11 (product of path). Let X be a topological space and f, g be paths. f and g are composable if $f(1) = g(0)$. If f and g are composable, their product $f \cdot g : I \rightarrow X$ is defined by

$$f \cdot g(s) = \begin{cases} f(2s) & 0 \leq s \leq \frac{1}{2} \\ g(2s - 1) & \frac{1}{2} \leq s \leq 1 \end{cases}$$

Proposition 1.12. Let X be a topological space and f_0, f_1, g_0, g_1 be paths in X such that f_0, g_0 are composable and f_1, g_1 are composable. If $f_0 \simeq g_0$, $f_1 \simeq g_1$, then $f_0 \cdot g_0 \simeq f_1 \cdot g_1$.

Proof. Suppose the homotopy from f_0 to f_1 is given by F and the homotopy from g_0 to g_1 is given by G . Then the required homotopy H from $f_0 \cdot g_0$ to $f_1 \cdot g_1$ is given by

$$H(s, t) = \begin{cases} F(2s, t) & 0 \leq s \leq \frac{1}{2}, 0 \leq t \leq 1 \\ G(2s - 1, t) & \frac{1}{2} \leq s \leq 1, 0 \leq t \leq 1 \end{cases}$$

\square

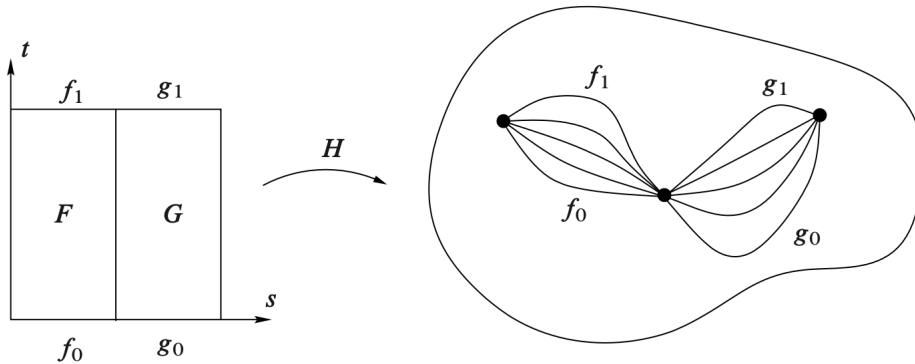

Proposition 1.13. Let X be a topological space and f, g be paths in X such that $f \simeq g$. If \bar{f} is the path obtained by reversing f , that is $\bar{f}(s) := f(1 - s)$, then $\bar{f} \simeq \bar{g}$.

Proof. Suppose f is homotopic to g by homotopy F . Then $G(s, t) := F(1 - s, t)$ is a homotopy from \bar{f} to \bar{g} since

$$\begin{aligned} G(s, 0) &= F(1 - s, 0) = f(1 - s) = \bar{f}(s) \\ G(s, 1) &= F(1 - s, 1) = g(1 - s) = \bar{g}(s) \end{aligned}$$

□

Remark 1.14. With above propositions, it makes sense to define the composition of path homotopy classes by setting $[\gamma_1] \cdot [\gamma_2] := [\gamma_1 \cdot \gamma_2]$, and use the notation $[\bar{\gamma}]$.

Proposition 1.15. Let X be a topological space and $[f], [g], [h]$ be homotopy classes of loops based at $p \in X$.

- (1) $[c_p] \cdot [f] = [f] \cdot [c_p] = [f]$, where c_p is constant loop based at p .
- (2) $[f] \cdot [\bar{f}] = [c_p]$ and $[\bar{f}] \cdot [f] = [c_p]$.
- (3) $[f] \cdot ([g] \cdot [h]) = ([f] \cdot [g]) \cdot [h]$.

Proof. For (1). Let us show that $c_p \cdot f \simeq f$, and the other case is similar. Define $H : I \times I \rightarrow X$ by

$$H(s, t) = \begin{cases} p & t \geq 2s \\ f\left(\frac{2s-t}{2-t}\right) & t \leq 2s \end{cases}$$

This map is continuous since $f(0) = p$, and it's clear to see $H(s, 0) = f(s)$ and $H(s, 1) = c_p \cdot f(s)$. Thus H gives the desired homotopy.

For (2). It suffices to show that $f \cdot \bar{f} \simeq c_p$, since the reverse path of \bar{f} is f , the other relation follows by interchanging the roles of f and \bar{f} . Define

$$H(s, t) = \begin{cases} f(2s) & 0 \leq s \leq \frac{t}{2} \\ f(t) & \frac{t}{2} \leq s \leq 1 - \frac{t}{2} \\ f(2 - 2s) & 1 - \frac{t}{2} \leq s \leq 1 \end{cases}$$

It is easy to check that H is a homotopy from c_p to $f \cdot \bar{f}$.

For (3). It suffices to show $(f \cdot g) \cdot h \simeq f \cdot (g \cdot h)$. The first path follows f and then g at quadruple speed for $s \in [0, \frac{1}{2}]$, and then follows h at double speed for $s \in [\frac{1}{2}, 1]$, while the second follows f at double speed and then g and h at quadruple speed. The two paths are therefore reparametrizations of each other and thus homotopic by Lemma 1.10.

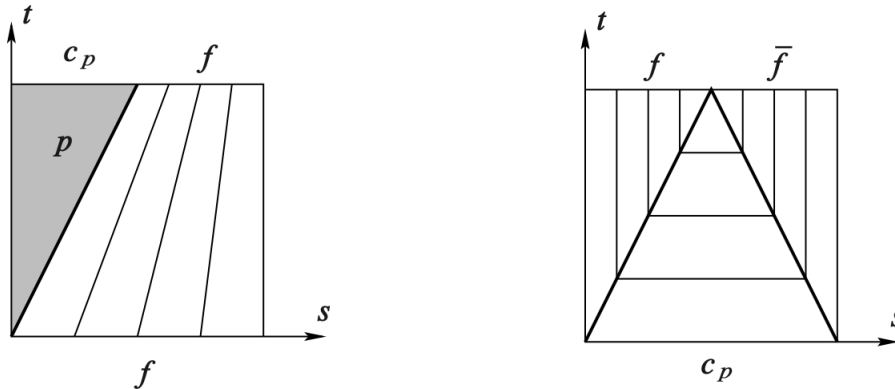

□

Definition 1.16 (fundamental group). *Let X be a topological space. The fundamental group of X based at $p \in X$, denoted by $\pi_1(X, p)$, is the set of path homotopy classes of loops based at p equipped with composition as its group structure.*

Theorem 1.17 (base point change). *Let X be a topological space, $p, q \in X$ and g is any path from p to q . The map*

$$\begin{aligned}\Phi_g : \pi_1(X, p) &\rightarrow \pi_1(X, q) \\ [f] &\mapsto [\bar{g}] \cdot [f] \cdot [g]\end{aligned}$$

is a group isomorphism with inverse $\Phi_{\bar{g}}$.

Proof. It suffices to show Φ_g is a group homomorphism, since it's clear $\Phi_g \circ \Phi_{\bar{g}} = \Phi_{\bar{g}} \circ \Phi_g = \text{id}$. For $[\gamma_1], [\gamma_2] \in \pi_1(X, p)$, one has

$$\begin{aligned}\Phi_g[\gamma_1] \cdot \Phi_g[\gamma_2] &= [\bar{g}] \cdot [\gamma_1] \cdot [g] \cdot [\bar{g}] \cdot [\gamma_2] \cdot [g] \\ &= [\bar{g}] \cdot [\gamma_1] \cdot [c_p] \cdot [\gamma_2] \cdot [g] \\ &= [\bar{g}] \cdot [\gamma_1] \cdot [\gamma_2] \cdot [g] \\ &= \Phi_g([\gamma_1] \cdot [\gamma_2])\end{aligned}$$

□

Corollary 1.18. *If X is a path-connected topological space, then its fundamental is independent of the choice of base point, and denoted by $\pi_1(X)$ for convenience.*

Definition 1.19. *If X is a path-connected topological space with $\pi_1(X) = 0$, then it's called simply-connected.*

Theorem 1.20. *The fundamental group of a topological manifold M is countable.*

Proof. Since M is second countable, there exists a countable cover \mathcal{U} of M consisting of coordinate balls, and for each $U, U' \in \mathcal{U}$ the intersection $U \cap U'$ has at most countably many components. We choose a point in each such component and let \mathcal{X} denote the (countable) set consisting of all the chosen points as U, U' range over all the sets in \mathcal{U} . For each $U \in \mathcal{U}$ and $x, x' \in \mathcal{X}$ such that $x, x' \in U$, choose a definite path $h_{x,x'}^U$ from x to x' in U .

Now choose any point $p \in \mathcal{X}$ as base point. Let us say that a loop based at p is special if it is a finite product of paths of the form $h_{x,x'}^U$. Because both \mathcal{U} and \mathcal{X} are countable sets, there are only countably many special loops. Each special loop determines an element of $\pi_1(M, p)$. If we can show that every element of $\pi_1(M, p)$ is obtained in this way, we are done, because we will have exhibited a surjective map from a countable set onto $\pi_1(M, p)$.

So suppose f is any loop based at p . By the Lebesgue number lemma there is an integer n such that f maps each subinterval $[(k-1)/n, k/n]$ into one of the balls in \mathcal{U} , which is called U_k . Let $f_k = f|_{[(k-1)/n, k/n]}$ reparametrized on the unit interval, so that $[f] = [f_1] \cdots [f_n]$.

For each $k = 1, \dots, n-1$, the point $f(k/n)$ lies in $U_k \cap U_{k+1}$. Therefore, there is some $x_k \in \mathcal{X}$ that lies in the same component of $U_k \cap U_{k+1}$ as $f(k/n)$. Choose a path g_k in $U_k \cap U_{k+1}$ from x_k to $f(k/n)$, and set $\tilde{f}_k = g_{k-1} \cdot f_k \cdot \bar{g}_k$ (taking $x_k = p$ and g_k to be the constant path c_p when $k = 0$ or n). It is immediate that $[f] = [\tilde{f}_1] \cdots [\tilde{f}_n]$, because all

the g_k 's cancel out. But for each k , \tilde{f}_k is a path in U_k from x_{k-1} to x_k , and since U_k is simply connected, \tilde{f}_k is path-homotopic to $h_{x_{k-1}x_k}^{U_k}$. This shows that f is path-homotopic to a special loop and completes the proof. \square

2. COVERING SPACE

In this section, we assume¹ all topological space are connected and locally path connected topological spaces, and all maps between them are continuous. References for this section are [Hat02] and [Lee10].

Definition 2.1 (covering space). *A covering space of X is a map $\pi : \tilde{X} \rightarrow X$ such that there exists a discrete space D and for each $x \in X$ an open neighborhood $U \subseteq X$, such that $\pi^{-1}(U) = \coprod_{d \in D} V_d$ and $\pi|_{V_d} : V_d \rightarrow U$ is a homeomorphism for each $d \in D$.*

- (1) *Such a U is called evenly covered by $\{V_d\}$.*
- (2) *The open sets $\{V_d\}$ are called sheets.*
- (3) *For each $x \in X$, the discrete subset $\pi^{-1}(x)$ is called the fiber of x .*
- (4) *The degree of the covering is the cardinality of the space D .*

Definition 2.2 (isomorphism between covering spaces). *Let $\pi_1 : \tilde{X}_1 \rightarrow X$ and $\pi_2 : \tilde{X}_2 \rightarrow X$ be two covering spaces. An isomorphism between covering spaces is a homeomorphism $f : \tilde{X}_1 \rightarrow \tilde{X}_2$ such that $\pi_1 = \pi_2 \circ f$.*

2.A. Proper map.

Definition 2.3 (proper). *Let $f : X \rightarrow Y$ be a continuous map between topological spaces. f is called proper if preimage of any compact set in Y is a compact subset in X .*

Lemma 2.4. *Let $p : X \rightarrow Y$ be a proper map between topological spaces and Y be locally compact and Hausdorff. Then p is a closed map.*

Proof. Let C be a closed subset of X . We need to prove that $p(C)$ is closed in Y , that is to prove $Y \setminus p(C)$ is open. Let $y \in Y \setminus p(C)$. Then y has an compact neighborhood V since Y is locally compact. Then $p^{-1}(V)$ is compact since f is proper. Let $E = C \cap p^{-1}(V)$. Then E is a compact and hence so is $p(E)$. Then $p(E)$ is closed since compact set in Hausdorff space is closed. Let $U = V \setminus p(E)$. Then U is an open neighborhood of y and disjoint from $p(C)$. This shows $Y \setminus p(C)$ is open as desired. \square

Corollary 2.5. *Let $p : X \rightarrow Y$ be a proper map between topological spaces and Y be locally compact and Hausdorff. If $y \in Y$ and V is an open neighborhood of $p^{-1}(y)$, then there exists an open neighborhood U of y with $p^{-1}(U) \subseteq V$.*

Proof. Since V is open, one has $X \setminus V$ is closed, and thus $A := p(X \setminus V)$ is also closed with $y \notin A$ since p is a closed map by Lemma 2.4. Thus $U := Y \setminus A$ is an open neighborhood of y such that $p^{-1}(U) \subseteq V$. \square

Theorem 2.6. *Let $p : X \rightarrow Y$ be a proper local homeomorphism between topological spaces and Y be locally compact and Hausdorff. Then p is a covering map.*

Proof. For $y \in Y$, one has $\{y\}$ is a compact set since Y is locally compact and Hausdorff, and hence so is $p^{-1}(y)$ since p is proper. On the other hand, $p^{-1}(y)$ is a discrete set since p is a local homeomorphism. Then $p^{-1}(y)$ is a finite set, and we denote it by

¹We are including these hypotheses since most of the interesting results (such as lifting criterion) require them, and most of the interesting topological space (such as connected topological manifold) satisfy them. In fact, it's almost the strongest connected hypotheses, since if a topological space is connected and locally path-connected, then it's also path connected.

$\{x_1, \dots, x_n\}$. Since p is a local homeomorphism, for each $i = 1, \dots, n$, there exists an open neighborhood W_i of x_i and an open neighborhood U_i of y such that $p|_{W_i}$ is a homeomorphism. Without loss of generality we may assume W_i are pairwise disjoint. Now $W_1 \cup \dots \cup W_n$ is an open neighborhood of $p^{-1}(y)$. Thus by Corollary 2.5 there exists an open neighborhood $U \subseteq U_1 \cap \dots \cap U_n$ of y with $p^{-1}(U) \subseteq W_1 \cup \dots \cup W_n$. If we let $V_i = W_i \cap p^{-1}(U)$, then the V_i are disjoint open sets with

$$p^{-1}(U) = V_1 \cup \dots \cup V_n$$

and all the mappings $p|_{V_i}$ are homeomorphisms. This shows p is a covering map. \square

2.B. The lifting theorems.

Proposition 2.7 (unique lifting property). *Let $\pi : \tilde{X} \rightarrow X$ be a covering space and a map $f : Y \rightarrow X$. If two lifts $\tilde{f}_1, \tilde{f}_2 : Y \rightarrow \tilde{X}$ of f agree at one point of Y , then \tilde{f}_1 and \tilde{f}_2 agree on all of Y .*

Proof. Let A be the set consisting of points of Y where \tilde{f}_1 and \tilde{f}_2 agree. If \tilde{f}_1 agrees with \tilde{f}_2 at some point of Y , then A is not empty, and we may assume $A \neq Y$, otherwise there is nothing to prove. For $y \notin A$, let \tilde{U}_1 and \tilde{U}_2 be the sheets containing $\tilde{f}_1(y)$ and $\tilde{f}_2(y)$ respectively. By continuity of \tilde{f}_1 and \tilde{f}_2 , there exists a neighborhood N of y mapped into \tilde{U}_1 by \tilde{f}_1 and mapped into \tilde{U}_2 by \tilde{f}_2 . Since $\tilde{f}_1(y) \neq \tilde{f}_2(y)$, then $\tilde{U}_1 \cap \tilde{U}_2 = \emptyset$. This shows $\tilde{f}_1 \neq \tilde{f}_2$ throughout the neighborhood N , and thus $Y \setminus A$ is open, that is A is closed. To see A is open, for $y \in A$ one has $\tilde{f}_1(y) = \tilde{f}_2(y)$, and thus $\tilde{U}_1 = \tilde{U}_2$. Since $\pi|_{\tilde{U}_1}$ is a diffeomorphism, one has $\tilde{f}_1 = \pi^{-1} \circ f = \tilde{f}_2$ on \tilde{U}_1 . This shows the set A is open, and thus $A = Y$ since Y is connected. \square

Theorem 2.8 (homotopy lifting property). *Let $\pi : \tilde{X} \rightarrow X$ be a covering space and $F : Y \times I \rightarrow X$ be a homotopy. If there exists a map $\tilde{F} : Y \times \{0\} \rightarrow \tilde{X}$ which lifts $F|_{Y \times \{0\}}$, then there exists a unique homotopy $\tilde{F} : Y \times I \rightarrow \tilde{X}$ which lifts F and restricting to the given \tilde{F} on $Y \times \{0\}$. Furthermore, if F is stationary on A , so is \tilde{F} .*

Proof. Firstly, let's construct a lift $\tilde{F} : N \times I \rightarrow \tilde{X}$ for some neighborhood N in Y of a given point $y_0 \in Y$. Since F is continuous, every point $(y_0, t) \in Y \times I$ has a product neighborhood $N_t \times (a_t, b_t)$ such that $F(N_t \times (a_t, b_t))$ is contained in an evenly covered neighborhood of $F(y_0, t)$. By compactness of $\{y_0\} \times I$, finitely many such products $N_t \times (a_t, b_t)$ cover $\{y_0\} \times I$. This implies that we can choose a single neighborhood N of y_0 and a partition $0 = t_0 < t_1 < \dots < t_m = 1$ of I such that for each i , one has $F(N \times [t_i, t_{i+1}])$ is contained in an evenly covered neighborhood U_i . Suppose \tilde{F} has been constructed on $N \times [0, t_i]$, starting with the given \tilde{F} on $N \times \{0\}$. Since U_i is evenly covered, there is an open set \tilde{U}_i of \tilde{X} projecting homeomorphically onto U_i by π and containing the point $\tilde{F}(y_0, t_i)$. After replacing N by a smaller neighborhood of y_0 we may assume that $\tilde{F}(N \times \{t_i\})$ is contained in \tilde{U}_i . Now we can define \tilde{F} on $N \times [t_i, t_{i+1}]$ to be the composition of F with the homeomorphism $\pi^{-1} : U_i \rightarrow \tilde{U}_i$ since $F(N \times [t_i, t_{i+1}]) \subseteq U_i$. After a finite number of steps we eventually get a lift $\tilde{F} : N \times I \rightarrow \tilde{X}$ for some neighborhood N of y_0 .

Next we show the uniqueness part in the special case that Y is a point, since in this case we can omit Y from the notation. Suppose \tilde{F} and \tilde{F}' are two lifts of $F : I \rightarrow X$ such that $\tilde{F}(0) = \tilde{F}'(0)$. As before, choose a partition $0 = t_0 < t_1 < \dots < t_m = 1$ of I so that for each

i , one has $F([t_i, t_{i+1}])$ is contained in some evenly covered neighborhood U_i . Assume inductively that $\tilde{F} = \tilde{F}'$ on $[0, t_i]$. Since $[t_i, t_{i+1}]$ is connected, so is $\tilde{F}([t_i, t_{i+1}])$, which must therefore lie in a single one of the disjoint open sets \tilde{U}_i projecting homeomorphically to U_i . Similarly, $\tilde{F}'([t_i, t_{i+1}])$ lies in a single \tilde{U}_i , in fact in the same one that contains $\tilde{F}([t_i, t_{i+1}])$ since $\tilde{F}'(t_i) = \tilde{F}(t_i)$. Because π is injective on \tilde{U}_i and $\pi \circ \tilde{F} = \pi \circ \tilde{F}'$, it follows that $\tilde{F} = \tilde{F}'$ on $[t_i, t_{i+1}]$, and the induction step is finished.

The last step in the proof of is to observe that since the \tilde{F} constructed above on sets of the form $N \times I$ are unique when restricted to each segment $\{y\} \times I$, they must agree whenever two such sets $N \times I$ overlap. So we obtain a well-defined lift \tilde{F} on all of $Y \times I$. This \tilde{F} is continuous since it is continuous on each $N \times I$, and \tilde{F} is unique since it is unique on each segment $\{y\} \times I$. \square

Corollary 2.9 (path lifting property). *Let $\pi : \tilde{X} \rightarrow X$ be a covering space. Suppose $\gamma : I \rightarrow X$ is any path, and $\tilde{x} \in \tilde{X}$ is any point in the fiber of $\pi^{-1}(\gamma(0))$. Then there exists a unique lift $\tilde{\gamma} : I \rightarrow \tilde{X}$ of γ such that $\tilde{\gamma}(0) = \tilde{x}$.*

Proof. Let Y be a point and F be the path γ in Theorem 2.8. \square

Corollary 2.10 (monodromy theorem). *Let $\pi : \tilde{X} \rightarrow X$ be a covering space. Suppose γ_1 and γ_2 are paths in X which are homotopic, and $\tilde{\gamma}_1, \tilde{\gamma}_2$ are their lifts with the same initial point. Then $\tilde{\gamma}_1$ is homotopic to $\tilde{\gamma}_2$.*

Proof. Suppose $F : I \times I \rightarrow X$ is the homotopy from γ_1 to γ_2 which is stationary on $\{0, 1\}$ and $\tilde{\gamma}_1, \tilde{\gamma}_2$ are lifts of γ_1, γ_2 with the same initial point. Then by Theorem 2.8 there exists a homotopy $\tilde{F} : I \times I \rightarrow \tilde{X}$ from $\tilde{\gamma}_1$ to $\tilde{\gamma}_2$ which is also stationary on $\{0, 1\}$, which shows $\tilde{\gamma}_1$ is homotopic to $\tilde{\gamma}_2$. \square

Corollary 2.11. *Let $\pi : (\tilde{X}, \tilde{x}_0) \rightarrow (X, x_0)$ be a covering space. Then*

- (1) *The map $\pi_* : \pi_1(\tilde{X}, \tilde{x}_0) \rightarrow \pi_1(X, x_0)$ is injective.*
- (2) *$\pi_*(\pi_1(\tilde{X}, \tilde{x}_0))$ consists of the homotopy class of loops in X whose lifts to \tilde{X} are still loops.*
- (3) *The index of $\pi_*(\pi_1(\tilde{X}, \tilde{x}_0))$ in $\pi_1(X, x_0)$ is the degree of covering. In particular, the degree of universal covering equals $|\pi_1(X, x_0)|$.*

Proof. For (1). An element of $\ker \pi_*$ is represented by a loop $\tilde{\gamma}_0 : I \rightarrow \tilde{X}$ with a homotopy F of $\gamma_0 = \pi \circ \tilde{\gamma}_0$ to the trivial loop γ_1 . By Theorem 2.8 there is a lifted homotopy of loops \tilde{F} starting with $\tilde{\gamma}_0$ and ending with a constant loop. Hence $[\tilde{\gamma}_0] = 0$ in $\pi_1(\tilde{X}, \tilde{x}_0)$ and π_* is injective.

For (2). The loops at x_0 lifting to loops at \tilde{x}_0 certainly represent elements of the image of $\pi_* : \pi_1(\tilde{X}, \tilde{x}_0) \rightarrow \pi_1(X, x_0)$. Conversely, a loop representing an element of the image of π_* is homotopic to a loop having such a lift, so by Theorem 2.8, the loop itself must have such a lift.

For (3). For a loop γ in X based at x_0 , let $\tilde{\gamma}$ be its lift to \tilde{X} starting at \tilde{x}_0 . A product $h \cdot \gamma$ with $[h] \in H = \pi_*(\pi_1(\tilde{X}, \tilde{x}_0))$ has the lift $\tilde{h} \cdot \tilde{\gamma}$ ending at the same point as $\tilde{\gamma}$ since \tilde{h} is a loop. Thus we may define a function Φ from cosets $H[\gamma]$ to $\pi^{-1}(x_0)$ by sending $H[\gamma]$ to $\tilde{\gamma}(1)$. The path-connectedness of \tilde{X} implies that Φ is surjective since \tilde{x}_0 can be joined to any point in $\pi^{-1}(x_0)$ by a path $\tilde{\gamma}$ projecting to a loop γ at x_0 . To see that Φ is injective, observe that $\Phi(H[\gamma_1]) = \Phi(H[\gamma_2])$ implies that $\gamma_1 \cdot \bar{\gamma}_2$ lifts to a loop in \tilde{X} based at \tilde{x}_0 , so

$[\gamma_1][\gamma_2]^{-1} \in H$ and hence $H[\gamma_1] = H[\gamma_2]$. Thus the index of H is the same as $|\pi^{-1}(x_0)|$, which is the degree of the covering. \square

Proposition 2.12 (lifting criterion). *Let $\pi : (\tilde{X}, \tilde{x}_0) \rightarrow (X, x_0)$ be a covering space and $f : (Y, y_0) \rightarrow (X, x_0)$ be a map. A lift $\tilde{f} : (Y, y_0) \rightarrow (\tilde{X}, \tilde{x}_0)$ of f exists if and only if $f_*(\pi_1(Y, y_0)) \subseteq \pi_*(\pi_1(\tilde{X}, \tilde{x}_0))$.*

Proof. The only if" statement is obvious since $f_* = \pi_* \circ f_*$. Conversely, let $y \in Y$ and let γ be a path in Y from y_0 to y . By Corollary 2.9, the path $f\gamma$ in X starting at x_0 has a unique lift $\tilde{f}\gamma$ starting at \tilde{x}_0 , and we define $\tilde{f}(y) = \tilde{f}\gamma(1)$.

To see it's well-defined, let γ' be another path from y_0 to y . Then $(f\gamma') \cdot \overline{(f\gamma)}$ is a loop h_0 at x_0 with $[h_0] \in f_*(\pi_1(Y, y_0)) \subseteq \pi_*(\pi_1(\tilde{X}, \tilde{x}_0))$. This means there is a homotopy H of h_0 to a loop h_1 that lifts to a loop \tilde{h}_1 in \tilde{X} based at \tilde{x}_0 . Apply Theorem 2.8 to H to get a lifting \tilde{H} . Since \tilde{h}_1 is a loop at \tilde{x}_0 , so is \tilde{h}_0 . By Proposition 2.7, that is uniqueness of lifted paths, the first half of \tilde{h}_0 is $\tilde{f}\gamma'$ and the second half is $\tilde{f}\gamma$ traversed backwards, with the common midpoint $\tilde{f}\gamma(1) = \tilde{f}\gamma'(1)$. This shows \tilde{f} is well-defined.

To see \tilde{f} is continuous, let $U \subseteq X$ be an open neighborhood of $f(y)$ having a lift $\tilde{U} \subseteq \tilde{X}$ containing $\tilde{f}(y)$ such that $\pi : \tilde{U} \rightarrow U$ is a homeomorphism. Choose a path-connected open neighborhood V of y with $f(V) \subseteq U$. For paths from y_0 to points $y' \in V$, we can take a fixed path γ from y_0 to y followed by paths η in V from y to points y' . Then the paths $(f\gamma) \cdot (f\eta)$ in X have lifts $(\tilde{f}\gamma) \cdot (\tilde{f}\eta)$ where $\tilde{f}\eta = \pi^{-1}f\eta$. Thus $\tilde{f}(V) \subseteq \tilde{U}$ and $\tilde{f}|_V = \pi^{-1}f$, so \tilde{f} is continuous at y . \square

Corollary 2.13. *Let $\pi : \tilde{X} \rightarrow X$ be a covering space and Y be a simply-connected space. Then every map $f : Y \rightarrow X$ has a lift.*

Proof. It's clear $f_*(\pi_1(Y, y_0)) \subseteq \pi_*(\pi_1(\tilde{X}, \tilde{x}_0))$ since $\pi_1(Y, y_0) = 0$. \square

Theorem 2.14. *Suppose X is a topological manifold, E is a Hausdorff space and $\pi : E \rightarrow X$ is a local homeomorphism with the path lifting property. Then π is a covering space.*

Proof. See Theorem 4.19 of [For91]. \square

2.C. The classification of the covering spaces.

Definition 2.15 (universal covering). *A simply-connected covering space of X is called universal covering.*

Definition 2.16 (semilocally simply-connected). *A topological space X is called semilocally simply-connected if each $x \in X$ has a neighborhood U such that the inclusion induced map $\pi_1(U, x) \rightarrow \pi_1(X, x)$ is trivial.*

Theorem 2.17. *If X is a semilocally simply-connected topological space, then X has a universal covering \tilde{X} .*

Proof. See construction in page 64 of [Hat02]. \square

Proposition 2.18. *Suppose X is a semilocally simply-connected topological space. Then for every subgroup $H \subseteq \pi_1(X, x_0)$, there exists a covering space $\pi : X_H \rightarrow X$ such that $\pi_*(\pi_1(X_H, \tilde{x}_0)) = H$ for a suitably chosen based point $\tilde{x}_0 \in X_H$.*

Proof. See Proposition 1.36 of [Hat02]. \square

Lemma 2.19. *Let $\pi_1 : \tilde{X}_1 \rightarrow X$ and $\pi_2 : \tilde{X}_2 \rightarrow X$ be two coverings. There exists an isomorphism $f : \tilde{X}_1 \rightarrow \tilde{X}_2$ taking a basepoint $\tilde{x}_1 \in \pi_1^{-1}(x_0)$ to a basepoint $\tilde{x}_2 \in \pi_2^{-1}(x_0)$ if and only if $\pi_{1*}(\pi_1(\tilde{X}_1, \tilde{x}_1)) = \pi_{2*}(\pi_1(\tilde{X}_2, \tilde{x}_2))$.*

Proof. If there is an isomorphism $f : (\tilde{X}_1, \tilde{x}_1) \rightarrow (\tilde{X}_2, \tilde{x}_2)$, then from the two relations $\pi_1 = \pi_2 \circ f$ and $\pi_2 = \pi_1 \circ f^{-1}$ it follows that $\pi_{1*}(\pi_1(\tilde{X}_1, \tilde{x}_1)) = \pi_{2*}(\pi_1(\tilde{X}_2, \tilde{x}_2))$. Conversely, suppose that $\pi_{1*}(\pi_1(\tilde{X}_1, \tilde{x}_1)) = \pi_{2*}(\pi_1(\tilde{X}_2, \tilde{x}_2))$. By Proposition 2.12, that is lifting criterion, we may lift π_1 to a map $\tilde{\pi}_1 : (\tilde{X}_1, \tilde{x}_1) \rightarrow (\tilde{X}_2, \tilde{x}_2)$ with $\pi_2 \circ \tilde{\pi}_1 = \pi_1$. Similarly, one has $\tilde{\pi}_2 : (\tilde{X}_2, \tilde{x}_2) \rightarrow (\tilde{X}_1, \tilde{x}_1)$ with $\pi_1 \circ \tilde{\pi}_2 = \pi_2$. Then Proposition 2.7, that is the unique lifting property, $\tilde{\pi}_1 \circ \tilde{\pi}_2 = \text{id}$ and $\tilde{\pi}_2 \circ \tilde{\pi}_1 = \text{id}$ since these composed lifts fix the basepoints. \square

Lemma 2.20. *For covering $\pi : (\tilde{X}, \tilde{x}_0) \rightarrow (X, x_0)$, changing the basepoint \tilde{x}_0 within $\pi^{-1}(x_0)$ corresponds exactly to changing $\pi_*(\pi_1(\tilde{X}, \tilde{x}_0))$ to a conjugate subgroup of $\pi_1(X, x_0)$.*

Proof. Let \tilde{x}_1 be another basepoint in $\pi^{-1}(x_0)$ and $\tilde{\gamma}$ be a path from \tilde{x}_0 to \tilde{x}_1 . Then $\tilde{\gamma}$ projects to a loop γ in X representing some element $g \in \pi_1(X, x_0)$. If we denote $H_i = \pi_*(\pi_1(\tilde{X}, \tilde{x}_i))$ for $i = 0, 1$, there is an inclusion $g^{-1}H_0g \subseteq H_1$ since if \tilde{f} is a loop at \tilde{x}_0 , one has $\tilde{\gamma}^{-1} \cdot \tilde{f} \cdot \tilde{\gamma}$ is a loop at \tilde{x}_1 . Similarly one has $gH_1g^{-1} \subseteq H_0$. This shows changing the basepoint from \tilde{x}_0 to \tilde{x}_1 changes H_0 to the conjugate subgroup $H_1 = g^{-1}H_0g$. \square

Theorem 2.21. *Let X be a semilocally simply-connected topological space. Then there is a bijection between the set of basepoint-preserving isomorphism classes of covering spaces $\pi : (\tilde{X}, \tilde{x}_0) \rightarrow (X, x_0)$ and the set of subgroups of $\pi_1(X, x_0)$ obtained by associating the subgroup $\pi_*(\pi_1(\tilde{X}, \tilde{x}_0))$ to the covering space (\tilde{X}, \tilde{x}_0) . If basepoints are ignored, this correspondence gives a bijection between isomorphism classes of covering spaces $\pi : \tilde{X} \rightarrow X$ and conjugacy classes of subgroups of $\pi_1(X, x_0)$.*

Proof. Proposition 2.18 and Lemma 2.19 completes the proof of the first half, and Lemma 2.20 completes the proof of the last half. \square

Corollary 2.22. *Let X be a semilocally simply-connected topological space. Then the universal covering of X is unique up to isomorphism.*

2.D. The structure of the deck transformation group.

Definition 2.23 (deck transformation). *Let $\pi : \tilde{X} \rightarrow X$ be a covering space. The deck transformation group is following set*

$$\text{Aut}_\pi(\tilde{X}) = \{f : \tilde{X} \rightarrow \tilde{X} \text{ is homeomorphism} \mid \pi \circ f = \pi\}$$

equipped with composition as group operation.

Proposition 2.24. *Let $\pi : \tilde{X} \rightarrow X$ be a covering space. The deck transformation group $\text{Aut}_\pi(\tilde{X})$ acts on \tilde{X} freely.*

Proof. Suppose $f : \tilde{X} \rightarrow \tilde{X}$ is a deck transformation admitting a fixed point. Since $\pi \circ f = \pi$, we may regard f as a lift of π , and identity map of \tilde{X} is another lift of π . By Proposition 2.7, that is unique lifting property, one has f is exactly identity map since it agrees with identity map at fixed point. \square

Definition 2.25 (normal). A covering $\pi : \tilde{X} \rightarrow X$ is called normal, if any deck transformation acts transitively on each fiber of $x \in X$.

Proposition 2.26. If $\pi : \tilde{X} \rightarrow X$ is a normal covering, then $\tilde{X}/\text{Aut}_\pi(\tilde{X})$ is homeomorphic to X .

Proof. Let $\Phi : \tilde{X}/\text{Aut}_\pi(\tilde{X}) \rightarrow X$ be the map sending the orbit $\mathcal{O}_{\tilde{x}}$ to $\pi(\tilde{x})$, where $\tilde{x} \in \tilde{X}$. It's clear Φ is well-defined bijection since $\text{Aut}_\pi(\tilde{X})$ acts on \tilde{X} fiberwise transitive, and the following diagram commutes

$$\begin{array}{ccc} \tilde{X} & & \\ p \downarrow & \searrow \pi & \\ \tilde{X}/\text{Aut}_\pi(\tilde{X}) & \xrightarrow{\Phi} & X \end{array}$$

This diagram shows Φ is both continuous and open, since p is the quotient map and π is continuous and open, which shows $\tilde{X}/\text{Aut}_\pi(\tilde{X})$ is homeomorphic to X . \square

Proposition 2.27. Let $\pi : (\tilde{X}, \tilde{x}_0) \rightarrow (X, x_0)$ be a covering space and $H = \pi_*(\pi_1(\tilde{X}, \tilde{x}_0)) \subseteq \pi_1(X, x_0)$. Then

- (1) π is a normal covering if and only if H is a normal subgroup of $\pi_1(X, x_0)$.
- (2) $\text{Aut}_\pi(\tilde{X})$ is isomorphic to the quotient $N(H)/H$, where $N(H)$ is the normalizer of H in $\pi_1(X, x_0)$.

In particular, $\text{Aut}_\pi(\tilde{X}) \cong \pi_1(X, x_0)$ if \tilde{X} is universal covering.

Proof. For (1). By proof of Lemma 2.20 one has changing the basepoint $\tilde{x}_0 \in \pi^{-1}(x_0)$ to $\tilde{x}_1 \in \pi^{-1}(x_0)$ corresponds precisely to conjugating H by an element $[\gamma] \in \pi_1(X, x_0)$ where γ lifts to a path $\tilde{\gamma}$ from \tilde{x}_0 to \tilde{x}_1 . Thus $[\gamma]$ is in the normalizer $N(H)$ if and only if $\pi_*(\pi_1(\tilde{x}, \tilde{x}_0)) = \pi_*(\pi_1(\tilde{x}, \tilde{x}_1))$, which is equivalent to the existence of a deck transformation taking \tilde{x}_0 to \tilde{x}_1 by Lemma 2.19. Thus the covering space is normal if and only if $N(H) = \pi_1(X, x_0)$, that is, $H \subseteq \pi_1(X, x_0)$ is a normal subgroup.

For (2). Define $\varphi : N(H) \rightarrow \text{Aut}_\pi(\tilde{X})$ by sending $[\gamma]$ to the deck transformation τ taking \tilde{x}_0 to \tilde{x}_1 , in the notation above. Let's show φ is a homomorphism. If γ' is another loop corresponding to the deck transformation τ' taking \tilde{x}_0 to \tilde{x}'_1 , then $\gamma \cdot \gamma'$ lifts to $\tilde{\gamma} \cdot (\tau(\tilde{\gamma}'))$, a path from \tilde{x}_0 to $\tau(\tilde{x}'_1) = \tau\tau'(\tilde{x}_0)$, so $\tau\tau'$ is the deck transformation corresponding to $[\gamma][\gamma']$. By the proof of (1) one has φ is surjective. The kernel of φ consists of classes $[\gamma]$ lifting to loops in \tilde{x} , which are exactly the elements of $\pi_*(\pi_1(\tilde{X}, \tilde{x}_0)) = H$. \square

Corollary 2.28. Let X be a topological space and $\pi : \tilde{X} \rightarrow X$ be its universal covering space. Then the quotient space $\tilde{X}/\pi_1(X)$ is homeomorphic X .

Proof. It follows from Proposition 2.26 since $\pi_1(X) \cong \text{Aut}_\pi(\tilde{X})$ if \tilde{X} is the universal covering. \square

2.E. Covering of manifold.

Lemma 2.29. Let X be a topological space admitting a countable open covering $\{U_i\}$ such that each set U_i is second countable in the subspace topology. Then X is second countable.

Proof. Let \mathcal{B}_α be a countable base for U_α . Its members are by definition open in U_α , and as all U_α are open in X , these sets are also open in X . So $\mathcal{B} = \bigcup_\alpha \mathcal{B}_\alpha$ is a countable family of open sets in X . Suppose that $x \in X$ and V is open in X with $x \in V$. Then $x \in U_\beta$ for some index β . Now apply the definition of a base to see that for some $B \in \mathcal{B}_\beta$ we have $x \in B \subseteq V \cap U_\beta$. This $B \in \mathcal{B}$ and $x \in B \subseteq V$. This shows that \mathcal{B} is a countable base for X . \square

Theorem 2.30. *Suppose M is a topological n -manifold and let $\pi : \tilde{M} \rightarrow M$ be a covering map. Then \tilde{M} is a topological n -manifold.*

Proof. Since π is a local diffeomorphism and M is locally Euclidean, one has \tilde{M} is also locally Euclidean. Now let's show \tilde{M} is Hausdorff, let \tilde{x}_1, \tilde{x}_2 be two distinct points in \tilde{M} . If $\pi(\tilde{x}_1) = \pi(\tilde{x}_2)$ and $U \subseteq M$ is an evenly covered open subset containing $\pi(\tilde{x}_1)$, then the component of $\pi^{-1}(U)$ containing \tilde{x}_1 and \tilde{x}_2 are disjoint open subsets of \tilde{M} that separate \tilde{x}_1 and \tilde{x}_2 . If $\pi(\tilde{x}_1) \neq \pi(\tilde{x}_2)$, there are disjoint open subsets $U_1, U_2 \subseteq M$ containing $\pi(\tilde{x}_1)$ and $\pi(\tilde{x}_2)$ since M is Hausdorff, and then $\pi^{-1}(U_1)$ and $\pi^{-1}(U_2)$ are disjoint open subsets of \tilde{M} containing \tilde{x}_1 and \tilde{x}_2 , and thus \tilde{M} is Hausdorff.

To see \tilde{M} is second countable, firstly note that each fiber of π is countable since by Corollary 2.11 one has the degree of covering less than or equal $|\pi(M, x)|$, and by Theorem 1.20 one has the fundamental group of a topological manifold is countable.

The collection of all evenly covered open subsets is an open covering of M , and therefore has a countable subcover $\{U_i\}$. For any given i , each component of $\pi^{-1}(U_i)$ contains exactly one point in each fiber over U_i , so $\pi^{-1}(U_i)$ has countably many components. The collection of all components of all sets of the form $\pi^{-1}(U_i)$ is a countable open covering of \tilde{M} . Since each such component is second countable, by Lemma 2.29 one has \tilde{M} is also second countable. \square

3. GROUP ACTION

3.A. Continuous action.

Definition 3.1 (group action). *Let G be a group and S be a set. A left G -action on S is a function*

$$\theta : G \times S \rightarrow S$$

satisfying the following two axioms:

- (1) $\theta(e, s) = s$, where $e \in G$ is the identity element.
- (2) $\theta(g_1, \theta(g_2, s)) = \theta(g_1 g_2, s)$, where $g_1, g_2 \in G$.

For convenience we denote $\theta(g, s) = gs$ for $g \in G, s \in S$.

Definition 3.2 (G -set). *Let G be a group. A set S endowed with a left (or right) G -action is called a left (or right) G -set.*

Definition 3.3 (orbit). *An orbit of a group action is the set of all images of a single element under the action by different group elements.*

Definition 3.4. *Let G be a group and S be a left G -set.*

- (1) *For $g \in G$, if $gs = s$ for some $s \in S$ implies $g = e$, then the group action is called free.*
- (2) *For $g \in G$, if $gs = s$ for all $s \in S$ implies $g = e$, then the group action is called effective.*
- (3) *If for arbitrary $s_1, s_2 \in S$, there exists $g \in G$ such that $gs_1 = s_2$, then the group action is called transitive.*

Remark 3.5. *If a group action is free, then it's effective, but converse statement may not hold.*

Definition 3.6 (isotropy group). *Let G be a group and S be a left G -set. For any $s \in S$, the isotropy group of s , denoted by G_s , is the set of all elements of G that fix s , that is*

$$G_s = \{g \in G \mid gs = s\}$$

Remark 3.7. *It's clear to see the action is free if and only if the isotropy group of every point is trivial.*

Definition 3.8 (act by homeomorphisms). *Let G be a group and X be a topological space. The group G is called acting X by homeomorphisms, if G acts on X , and for every $g \in G$, the map $x \mapsto gx$ is a homeomorphism.*

Definition 3.9 (topological group). *A group is called a topological group, if it's a topological space such that the multiplication and the inversion are continuous.*

Definition 3.10 (continuous action). *Let X be a topological space and G a topological group. A continuous G -action on X is given by the following data:*

- (1) *G acts on X by homeomorphisms.*
- (2) *The map $G \times X \rightarrow X$ given by $(g, x) \mapsto gx$ is continuous.*

Lemma 3.11. *Let X be a topological space and G a group acting on X by homeomorphisms. Then the quotient map $\pi : X \rightarrow X/G$ is an open map.*

Proof. For any $g \in G$ and any subset $U \subseteq X$, the set $gU \subseteq X$ is defined as

$$gU = \{gx \mid x \in U\}$$

If $U \subseteq X$ is open, then $\pi^{-1}(\pi(U))$ is the union of all sets of the form gU as g ranges over G . Since $p \mapsto gp$ is a homeomorphism, each set is open, and therefore $\pi^{-1}(\pi(U))$ is open in X . Since π is a quotient map, this implies $\pi(U)$ is open in X/G , and therefore π is an open map. \square

3.B. Proper action.

Definition 3.12 (proper). *Let X be a topological space and G a topological group. A continuous G -action on X is called proper if the continuous map*

$$\begin{aligned} \Theta : G \times X &\rightarrow X \times X \\ (g, x) &\mapsto (gx, x) \end{aligned}$$

is proper, that is, the preimage of a compact set is compact.

Lemma 3.13. *Let X, Y be topological spaces and $\pi : X \rightarrow Y$ be an open quotient map. Then Y is Hausdorff if and only if the set $\mathcal{R} = \{(x_1, x_2) \mid \pi(x_1) = \pi(x_2)\}$ is closed in $X \times X$.*

Proposition 3.14. *Let X be a topological space and G a topological group acting on X continuously. If the action is also proper, then the orbit space is Hausdorff.*

Proof. Let $\Theta : G \times X \rightarrow X \times X$ be the proper map $\Theta(g, x) = (gx, x)$ and $\pi : X \rightarrow X/G$ be the quotient map. Define the orbit relation $\mathcal{O} \subseteq X \times X$ by

$$\mathcal{O} = \Theta(G \times X) = \{(gx, x) \mid x \in X, g \in G\}$$

Since proper continuous map is closed, it follows that \mathcal{O} is closed in $X \times X$, and since π is open by Lemma 3.11, one has X/G is Hausdorff by Lemma 3.13. \square

Proposition 3.15. *Let M be a topological manifold and G a second countable topological group acting on M continuously. The following statements are equivalent.*

- (1) *The action is proper.*
- (2) *If $\{p_i\}$ is a sequence in M and $\{g_i\}$ is a sequence in G such that both $\{p_i\}$ and $\{g_i p_i\}$ converge, then a subsequence of $\{g_i\}$ converges.*
- (3) *For every compact subset $K \subseteq M$, the set $G_K = \{g \in G \mid gK \cap K \neq \emptyset\}$ is compact.*

Proof. Along the proof, let $\Theta : G \times M \rightarrow M \times M$ denote the map $(g, p) \mapsto (gp, p)$. For (1) to (2). Suppose Θ is proper, and $\{p_i\}, \{g_i\}$ are sequences satisfying the hypotheses of (2). Let U and V be precompact² neighborhoods of $p = \lim_i p_i$ and $q = \lim_i g_i p_i$. The assumption implies $\Theta(g_i, p_i)$ all lie in compact set $\overline{U} \times \overline{V}$ when i is sufficiently large, so there exists a subsequence of $\{(g_i, p_i)\}$ converges in $G \times M$ since Θ is proper. In particular, this means that a subsequence of $\{g_i\}$ converges in G .

For (2) to (3). Since G is second countable, it suffices to show it's sequential compact. Let K be a compact subset of M , and suppose $\{g_i\}$ is any sequence in G_K . This means for each i , there exists $p_i \in g_i K \cap K$, which is to say that $p_i \in K$ and $g_i^{-1} p_i \in K$. By passing to a subsequence twice, we may assume both $\{p_i\}$ and $\{g_i^{-1} p_i\}$ converge, and the assumption

²A set is called precompact, if its closure is compact.

implies there exists a convergent subsequence of $\{g_i\}$. Since each sequence of G_K has a convergent subsequence, G_K is compact.

For (3) to (1). Suppose $L \subseteq M \times M$ is compact, and let $K = \pi_1(L) \cup \pi_2(L)$, where $\pi_1, \pi_2 : M \times M \rightarrow M$ are the projections onto the first and second factors, respectively. Then

$$\Theta^{-1}(L) \subseteq \Theta^{-1}(K \times K) = \{(g, p) \mid gp \in K, p \in K\} \subseteq G_K \times K$$

By assumption $G_K \times K$ is compact, and thus $\Theta^{-1}(L)$ is compact since it's a closed subset of a compact subset, which implies the action is proper. \square

Corollary 3.16. *Let M be a topological manifold and G a compact topological group. Then every continuous G -action on M is proper.*

Proof. Since G is compact, then every sequence in G admits a convergent subsequence, and thus the action is proper by (2) of Proposition 3.15. \square

3.C. Properly discontinuous action.

Definition 3.17 (properly discontinuous). *Let G be a group acting on a topological space X by homeomorphisms. The action is called properly discontinuous, if every point $x \in X$ has a neighborhood U such that for each $g \in G$, $gU \cap U = \emptyset$ unless $g = e$.*

Lemma 3.18. *Suppose G be a group acting properly discontinuous on a topological space X . Then every subgroup of G still acts properly discontinuous on X .*

Lemma 3.19. *Let $\pi : \tilde{X} \rightarrow X$ be a covering space. Then $\text{Aut}_\pi(\tilde{X})$ acts on \tilde{X} properly discontinuous.*

Proof. For $\tilde{x} \in \tilde{X}$, let $\tilde{U} \subseteq \tilde{X}$ be an open neighborhood of \tilde{x} projecting homeomorphically to $U \subseteq X$. If there exists $g \in \text{Aut}_\pi(\tilde{X})$ such that $g(\tilde{U}) \cap \tilde{U} \neq \emptyset$, then $g\tilde{x}_1 = \tilde{x}_2$ for some $\tilde{x}_1, \tilde{x}_2 \in \tilde{U}$. Since \tilde{x}_1 and \tilde{x}_2 lie in the same set $\pi^{-1}(x)$, which intersects \tilde{U} in only one point, we must have $\tilde{x}_1 = \tilde{x}_2 = \tilde{x}$. Then \tilde{x} is a fixed point of g , which implies $g = e$ since deck transformation acts freely (Proposition 2.24). \square

Proposition 3.20. *Suppose G is a discrete topological group acting continuously and freely on a topological manifold M . The action is proper if and only if the following conditions both hold.*

- (1) G acts on M properly discontinuous.
- (2) If $p, p' \in M$ are not in the same orbit, then there exist a neighborhood V of p and V' of p' such that $gV \cap V' = \emptyset$ for all $g \in G$.

Proof. Firstly, suppose that the action is free and proper and let $\pi : M \rightarrow M/G$ denote the quotient map. By Proposition 3.14, the orbit space M/G is Hausdorff. If $p, p' \in M$ are not in the same orbit, we can choose disjoint neighborhoods W of $\pi(p)$ and W' of $\pi(p')$, and then $V = \pi^{-1}(W)$ and $V' = \pi^{-1}(W')$ satisfy the conclusion of condition (2). To show G acts on M properly discontinuous, we need to show for each $p \in M$, there exists an open neighborhood U of p such that $gU \cap U = \emptyset$ unless $g = e$. Let V be a precompact neighborhood of p . By Proposition 3.15, the set $G_{\bar{V}}$ is a compact subset of G , and hence finite because G is discrete, so we write $G_{\bar{V}} = \{e, g_1, \dots, g_m\}$. Shrinking V if

necessary, we may assume that $g_i^{-1}p \notin \bar{V}$ for $i = 1, \dots, m$. Consider open subset

$$U = V \setminus (g_1\bar{V} \cup \dots \cup g_m\bar{V})$$

It's clear $gU \cap U = \emptyset$ unless $g = e$.

Conversely, assume that (1) and (2) hold. Suppose $\{g_i\}$ is a sequence in G and $\{p_i\}$ is a sequence in M such that $p_i \rightarrow p$ and $g_i p_i \rightarrow p'$. If p and p' are in different orbits, there exist neighborhoods V of p and V' of p' as in (2), but for large enough i , we have $p_i \in V$ and $g_i p_i \in V'$, which contradicts the fact that $g_i V \cap V' = \emptyset$. This shows p and p' are in the same orbit, so there exists $g \in G$ such that $gp = p'$. This implies $g^{-1}g_i p_i \rightarrow p$. Since G acts on M properly discontinuous, there exists an open neighborhood U such that $gU \cap U = \emptyset$ unless $g = e$. For large enough i , one has p_i and $g^{-1}g_i p_i$ are both in U , and by the choice of U one has $g^{-1}g_i = e$. So $g_i = g$ when i is large enough, which certainly converges. By (2) of Proposition 3.15, the action is proper. \square

Theorem 3.21. *Let M be a topological manifold and $\pi : \tilde{M} \rightarrow M$ be a normal covering space. If $\text{Aut}_\pi(\tilde{M})$ is equipped with the discrete topology, then it acts on \tilde{M} continuously, freely and properly.*

Proof. By Proposition 2.24 one has $\text{Aut}_\pi(\tilde{M})$ acts on \tilde{M} freely and the action is also continuously since $\text{Aut}_\pi(\tilde{M})$ is equipped with discrete topology. To see the action is properly, it suffices to show the action satisfies the two conditions in Proposition 3.20.

- (a) By Lemma 3.19, one already has $\text{Aut}_\pi(\tilde{M})$ acts on \tilde{M} properly discontinuous.
- (b) Since $\pi : \tilde{M} \rightarrow M$ is a normal covering, one has the orbit space is homeomorphic to M by Proposition 2.26 and thus orbit space is Hausdorff. If $\tilde{x}_1, \tilde{x}_2 \in \tilde{M}$ are in different orbits, we can choose disjoint neighborhoods W of $\pi(\tilde{x}_1)$ and W' of $\pi(\tilde{x}_2)$ since orbit space is Hausdorff, and it follows that $V = \pi^{-1}(W)$ and $V' = \pi^{-1}(W')$ satisfy the second condition. \square

REFERENCES

- [For91] Otto Forster. *Lectures on Riemann surfaces*, volume 81 of *Graduate Texts in Mathematics*. Springer-Verlag, New York, 1991. Translated from the 1977 German original by Bruce Gilligan, Reprint of the 1981 English translation.
- [Hat02] Allen Hatcher. *Algebraic topology*. Cambridge University Press, 2002.
- [Lee10] John Lee. *Introduction to topological manifolds*, volume 202. Springer Science & Business Media, 2010.

DEPARTMENT OF MATHEMATICS, TSINGHUA UNIVERSITY, BEIJING, 100084, P.R. CHINA,
Email address: liubw22@mails.tsinghua.edu.cn